

Lab Manual

EXPERIMENT NO. 2

Objective:

To investigate the relationship between shear stress and shear strain for rubber and to determine the modulus of rigidity of the material.

Apparatus:

Modulus of rigidity of rubber apparatus, Hangers and Weights, Steel rule, Dial Indicator

A rubber block is bonded to two aluminum alloy plates.

One plate is screwed to a wall, whilst the other has a shear load applied by a loaded weight hanger.

A dial gauge measures the deflection of the block.

This equipment is part of a range designed to both demonstrate and experimentally confirm basic engineering principles. Great care has been given to each item so as to provide wide experimental scope without unduly complicating or compromising the design. Each piece of apparatus is self-contained and compact. Setting up time is minimal, and all measurements are made with the simplest possible instrumentation, so that the student involvement is purely with the engineering principles being taught.

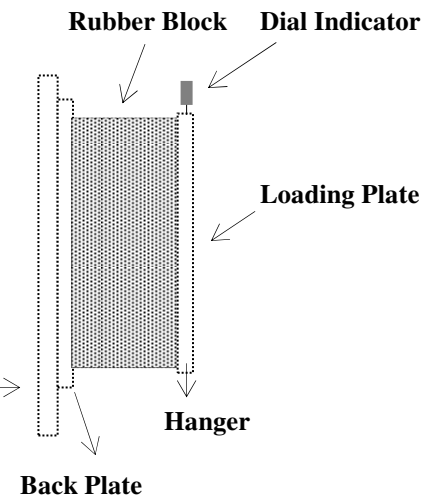

Figure (a)

Summary of Theory:

The force which tends to cut off or parts off one portion of the component from the other is called shear force. Stresses produced on the area under shear, due to shearing forces, are called shearing stresses. Shear stress is denoted by τ .

Mathematically,

$$\text{Shearing stress} = \text{Shearing force} / \text{Area under shear} \quad \text{----- (i)}$$

Units of shear stress: *Newton per square meter (N/m^2) = Pascal (Pa) or pounds per square inch (psi)*

Shearing strain is the angle of distortion. It can be represented by γ . ----- (ii)

The constant of proportionality relating shear stress and shear strain is modulus of rigidity. It is represented by **G**.

Mathematically,

$$G = \text{Shear stress} / \text{shear strain} \quad \text{----- (iii)}$$

Units of G: *Newton per square meter (N/m^2) = Pascal (Pa) or pounds per square inch (psi)*

Let us consider the deformation of a rectangular block where the forces acting on the block are known to be shearing stress as shown in the figure (b).

The change of angle at the corner of an originally rectangular element is defined as the shear strain.

Let,

- P_s = Shearing load or force acting on the body
- l = Length of the body
- A = Area under shear = $l \times t$
- τ = Shear stress induced in the body
- G = Modulus of rigidity for the material of the body
- γ = Shear strain produced
- δs = Deformation of the body

From the figure

$$Cc = Dd = \delta s = \text{Shear Deformation}$$

$$\tan \gamma = Dd/BD = \delta s/w$$

For smaller angles

$$\tan \gamma = \gamma = \text{Shear strain} = \delta s/w$$

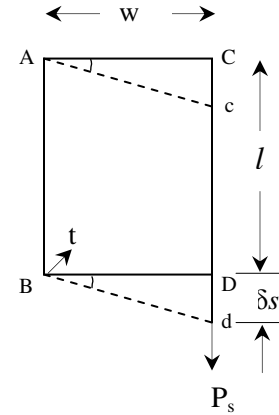

Figure (b): Distortion of a rectangular block

From the information in (i), (ii), and (iii)

$$G = \tau / \gamma$$

or

$$G = (P_s / \delta s) (w / Lt)$$

Shear Stress-Shear Strain Curve:

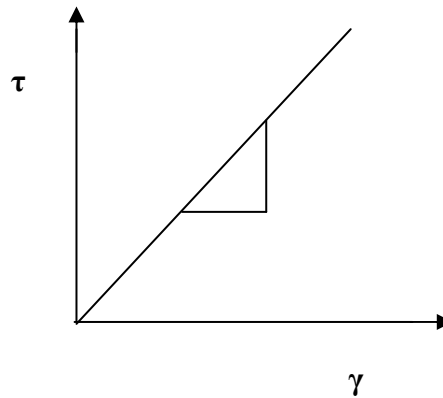

Procedure:

1. Set the dial indicator so that its anvil rests on the top of the loading plate.
2. Set the dial indicator at zero.
3. With the hanger in position apply a load to the hanger and read the vertical displacement of the loading plate relative to the fixing plate from the dial indicator (δs).
4. Repeat the experiment for increasing load and record the vertical displacement of the loading plate in each case.
5. Unload and note the corresponding readings with the load decreasing.
6. Calculate the “Modulus of Rigidity (**G**)” of the rubber material.

Observations and Calculations:

Length of rubber block (l) = _____ mm
 Width of rubber block (w) = _____ mm
 Thickness of rubber block (t) = _____ mm
 Least count of dial indicator = _____ mm

No. of Obs.	Load P_s (N)	Shear Deformation- δs (mm)			Shear Stress $\tau = P_s / l \cdot t$ (N/m ²)	Shear Strain $\gamma = \delta s / w$	Modulus of Rigidity	
		Loading	Unloading	Average			$G = \tau / \gamma$ (N/m ²)	G (N/m ²) <i>From Graph</i>
1.								
2.								
3.								
4.								
5.								
6.								
7.								

Name: _____

Reg. # _____

Date:

Report:

The laboratory report should contain the following:

1. Plot of curve between shear stress- τ (Y-axis) and shear strain- γ (X-axis). Calculate the slope of the graph.
2. Hand calculations showing all results requested in (6) under procedure above.
3. A discussion / comments of factors affecting the results of the experiment.
4. Practical Applications